

## SFP Transceivers - 155Mbps

### Description:

The S155 series are hot pluggable 3.3 V Small-Form-Factor (SFP) duplex, Bidirectional and CWDM transceiver modules designed expressly for high speed communication applications that require rates of up to 155 Mbps. Transceivers are compliant with the Fast Ethernet, ATM, SONET OC 3/SDH STM 1 standards. The 155 Mbps transceivers are manufactured with LC receptacle that is compatible with the industry LC connector standard. All SFP transceivers have the digital diagnostic monitor feature.



### Specifications:

	Unit	SX	LRM	LX	HX	ZX	UX
Average output power (min / max)	dBm	-9 / -3	-20 / -14	-15 / -8	-7 / -2	-5 / 0	-2 / 3
Receiver sensitivity	dBm	-24	-28	-29	-32	-33	-34
Overload	dBm	-6	-3	-8	-10	-10	-10
Maximum distance	km	0.550	1,5	20	40	80	120
Fiber type	-	MMF	MMF	SMF	SMF	SMF	SMF
Optical link budget	dBm	15	8	14	25	28	32
Wavelength / laser type	nm	850/VCSEL	1310 / FP	1310 / FP	1310 / FP, 1550 / DFB	1550 / DFB	1550 / DFB

Table 1: Basic technical specifications according to distance.

### Temperature:

OPTOKON is always trying to satisfy as much market demand as possible and with this in mind, almost all OPTOKON SFP transceivers are manufactured in the commercial (D), extended (E) and industrial (I) temperature ranges to provide you all possibilities you need for your application.

Code	Temperature
D	0 °C to + 70 °C
E	-10°C to + 80 °C
I	-40°C to + 85 °C

### Safety and regulatory compliance

Electrostatic discharge (ESD)	IEC/EN 61000-4-2
Electromagnetic Interference (EMI)	FCC Part 15 Class B EN 55022, Class B (CISPR 22A)
Laser Eye Safety	Class 1 laser product
Component Recognition	IEC/EN 60950, UL
ROHS	2002/95/EC
EMC	EN 61000-3

### Digital diagnostics:

All OPTOKON SFP transceiver are assembled with digital diagnostic feature as a standard.

## Transceiver dimensions schema

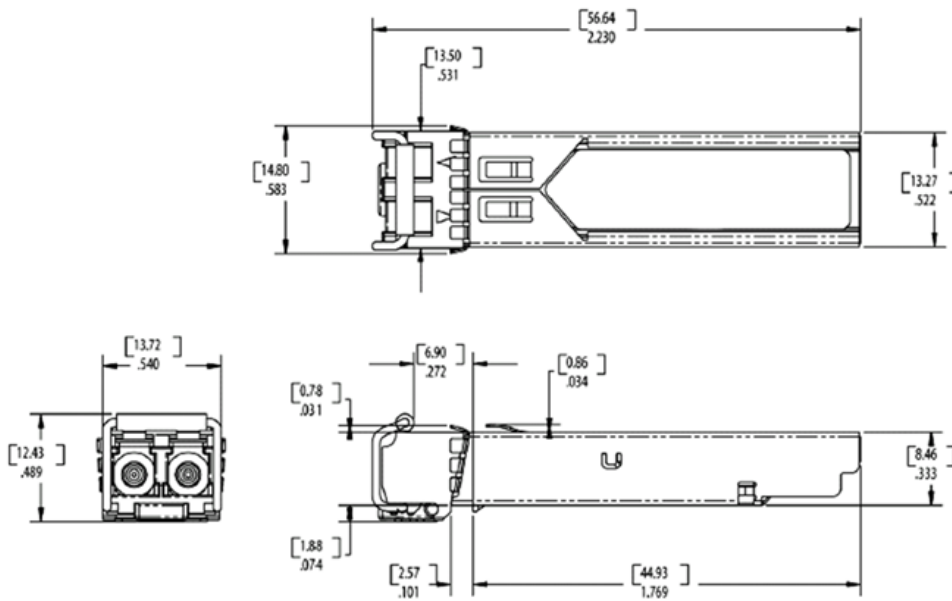

## Ordering codes for 155 Mbps SFP transceivers::

Standard series:

Part number:	Speed [Mbps]	Distance [km]	Wavelength [nm]	Temperature [-]	Fiber [-]	Connector [-]
M155-V85-LP-SX-D-XX	155	0.550	850	D, E, I	MMF	LC
M155-F31-LP-LRM-D-XX	155	1.5	1310	D, E, I	MMF	LC
S155-F31-LP-LX-D-XX	155	20	1310	D, E, I	SMF	LC
S155-F31-LP-HX-D-XX	155	40	1310	D, E, I	SMF	LC
S155-D55-LP-HX-D-XX	155	40	1550	D, E, I	SMF	LC
S155-D55-LP-ZX-D-XX	155	80	1550	D, E, I	SMF	LC
S155-D55-LP-UX-D-XX	155	120	1550	D	SMF	LC

Bidirectional series:

Part number:	Speed [Mbps]	Distance [km]	TX wavelength [nm]	Rx wavelength [nm]	Temperature [-]	Fiber [-]	Connector [-]
S155-W31/49-LP-LX-D-XX	155	20	1310	1490	D, E, I	SMF	LC
S155-W49/31-LP-LX-D-XX	155	20	1490	1310	D, E, I	SMF	LC
S155-W31/55-LP-LX-D-XX	155	20	1310	1550	D, E, I	SMF	LC
S155-W55/31-LP-LX-D-XX	155	20	1550	1310	D, E, I	SMF	LC
S155-W31/55-LP-HX-D-XX	155	40	1310	1550	D, E, I	SMF	LC
S155-W55/31-LP-HX-D-XX	155	40	1550	1310	D, E, I	SMF	LC
S155-W31/55-LP-ZX-D-XX	155	80	1310	1550	D, E, I	SMF	LC
S155-W55/31-LP-ZX-D-XX	155	80	1550	1310	D, E, I	SMF	LC
S155-W49/55-LP-UX-D-XX	155	120	1490	1550	D	SMF	LC
S155-W55/49-LP-UX-D-XX	155	120	1550	1490	D	SMF	LC

CWDM series:

Part number:	Speed [Mbps]	Distance [km]	Wavelength [nm]	Temperature [-]	Fiber [-]	Connector [-]
S155-Cyy-LP-HX-D-XX	155	40	CWDM	D, E, I	SMF	LC
S155-Cyy-LP-ZX-D-XX	155	80	CWDM	D, E, I	SMF	LC
S155-Cyy-LP-UX-D-XX	155	120	CWDM	D	SMF	LC

CWDM laser code:

yy/zz [-]	Wavelength [nm]	Clasp Color Code [-]	yy/zz [-]	Wavelength [nm]	Clasp Color Code [-]	dd code [-]	Distance [km]
27	1270	Grey	45	1450	Brown	SX	0.550
29	1290	Grey	47	1470	Grey	LRM	1.5
31	1310	Grey	49	1490	Purple	LX	20
33	1330	Purple	51	1510	Blue	HX	40
35	1350	Blue	53	1530	Green	ZX	80
37	1370	Green	55	1550	Yellow	UX	120
39	1390	Yellow	57	1570	Orange		
41	1410	Orange	59	1590	Red		
43	1430	Red	61	1610	Brown		

Table 3: Distance code.

Temperature code examples:

To order SFP with extended or industrial temperature, please add temperature mark at the end of ordering number.

Code	Description
S155-D55-LP-HX-E-XX	Standard series, 1550 nm, 40 km, -10 °C to +80 °C operational temperature
S155-W31/55-LP-LX-I-XX	Bidirectional SFP series, 1310 / 1550 nm, 20 km, -40 °C to +85 °C operational temperature