

SFP+ Transceivers - 6 Gbps

Description:

The OPTOKON transceivers are compliant with SFF-8432. This upgrade, and reliability benefits by virtue of being hot-pluggable, also is designed for single-mode and multimode fiber with cost effective and high performance. 6 Gbps SFP+ can be used for CIPRI (2.456, 4.915, 6.144 Gbps), LTE (4.915, 6.144 Gbps) or OBSAI (6.144 Gbps) applications.



Specifications:

	Unit	SR	LR02	LR	LR20	ER	ER60	ZR
Average output power (min / max)	dBm	-6 / -1	-6.5 / 0	-6.5 / 0	-6 / 0	-1 / 4	0 / 5	0 / 5
Receiver sensitivity	dBm	-15	-14	-14	-15	-15	-20	-23
Overload	dBm	-1	0	0	0.5	0.5	-6	-6
Maximum distance	km	0.300	2	10	20	40	60	80
Fiber type	-	MMF	SMF	SMF	SMF	SMF	SMF	SMF
Minimum optical link budget	dBm	9	7,5	7,5	9	14	20	23
Wavelength / laser type	nm	VCSEL	FP	DFB	DFB	DFB	DFB	DFB

Table 1: Basic technical specifications according to distance.

Temperature:

OPTOKON is always trying to satisfy as much market demand as possible and with this in mind, almost all OPTOKON SFP transceivers are manufactured in the **Commercial**, **Extended** and **Industrial** temperature ranges to provide you all possibilities you need for your application.

Code Temperature

D	0 °C to + 70 °C
E	-10°C to + 80 °C
I	-40°C to + 85 °C

Safety and regulatory compliance

Electrostatic discharge (ESD)	IEC/EN 61000-4-2
Electromagnetic Interference (EMI)	FCC Part 15 Class B EN 55022, Class B (CISPR 22A)
Laser Eye Safety	Class 1 laser product
Component Recognition	IEC/EN 60950, UL
ROHS	2002/95/EC
EMC	EN 61000-3

Digital diagnostics:

All OPTOKON SFP transceivers are assembled with digital diagnostic feature as a standard

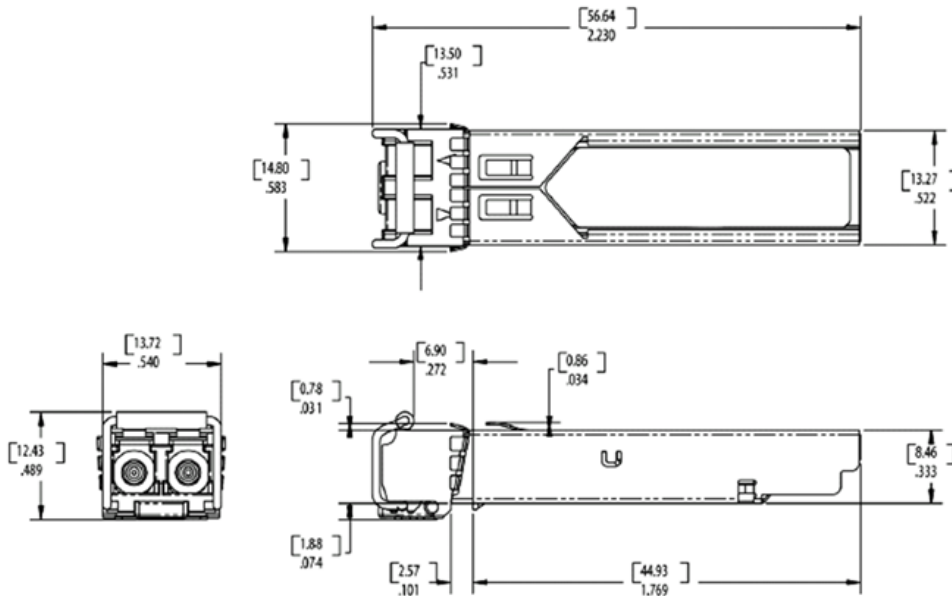

Application:

Accessories:

Ordering code:

Standard Series:

Part number:	Speed [Gbps]	Distance [km]	Wavelength [nm]	Temperature [-]	Fiber type [-]	Connector [-]
M6-V85-SP-SR-D-XX	6	0.300	850	D, E, I	SMF	LC
S6-F31-SP-LR02-D-XX	6	2	1310	D, E, I	SMF	LC
S6-D31-SP-LR-D-XX	6	10	1310	D, E, I	SMF	LC

DWDM Series:

Part number:	Speed [Gbps]	Distance dd [-]	Wavelength [-]	Temperature [-]	Fiber type [-]	Connector [-]
S6-Cyy-SP-ER-D-XX	8.5	40	DWDM	D	SMF	LC
S6-Cyy-SP-ZR-D-XX	8.5	80	DWDM	D	SMF	LC

DWDM laser code:

yy [-]	Frequency [THz]	Wavelength [nm]	yy [-]	Frequency [THz]	Wavelength [nm]	yy [-]	Frequency [THz]	Wavelength [nm]	yy [-]	Frequency [THz]	Wavelength [nm]
C17	191.7	1563.86	C29	192.9	1554.13	C40	194.0	1545.32	C51	195,,1	1536.61
C18	191.8	1563.05	C30	193.0	1553.33	C41	194.1	1544.53	C52	195,,2	1535.82
C19	191.9	1562.23	C31	193.1	1552.52	C42	194.2	1543.73	C53	195,,3	1535.04

C20	192.0	1561.42	C32	193.2	1551.72	C43	194.3	1542.94	C54	195,,4	1534.25
C21	192.1	1560.61	C33	193.3	1550.92	C44	194.4	1542.14	C55	195,,5	1533.47
C22	192.2	1559.79	C34	193.4	1550.12	C45	194.5	1541.35	C56	195,,6	1532.68
C23	192.3	1558.98	C35	193.5	1549.32	C46	194.6	1540.56	C57	195,,7	1531.90
C24	192.4	1558.17	C36	193.6	1548.51	C47	194.7	1539.77	C58	195,,8	1531.12
C25	192.5	1557.36	C37	193.7	1547.72	C48	194.8	1538.98	C59	195,,9	1530.33
C26	192.6	1556.55	C38	193.8	1546.92	C49	194.9	1538.19	C60	196,,0	1529.55
C27	192.7	1555.75	C39	193.9	1546.12	C50	195.0	1537.40	C61	196,,1	1528.77
C28	192.8	1554.94									

DWDM code examples:

Part number:	Speed [Gbps]	Distance dd [-]	Wavelength [nm]	Temperature [-]	Fiber type [-]	Connector [-]
S6-D63 86-SP-ER-D-XX	1.25	40	1563.86 (channel 17)	D	SMF	LC
S6-D59 79-SP-ER-D-XX	1.25	40	1559.79 (channel 22)	D	SMF	LC
S6-D58 98-SP-ER-D-XX	1.25	40	1558.98 (channel 23)	D	SMF	LC
S6-D54 94-SP-ZR-D-XX	1.25	80	1554.94 (channel 28)	D	SMF	LC
S6-D53 33-SP-ZR-D-XX	1.25	80	1553.33 (channel 30)	D	SMF	LC

CWDM Series:

Part number:	Speed [Gbps]	Distance dd [-]	Wavelength [-]	Temperature [-]	Fiber type [-]	Connector [-]
S6-Cyy-SP-LR-D-XX	8.5	10	CWDM -1270 ~ 1450	D	SMF	LC
S6-Cyy-SP-LR20-D-XX	8.5	20	CWDM -1270 ~ 1450	D	SMF	LC
S6-Cyy-SP-ER-D-XX	8.5	40	CWDM -1270 ~ 1370 CWDM -1470 ~ 1610	D	SMF	LC
S6-Cyy-SP-ER60-D-XX	8.5	60	CWDM -1270 ~ 1370	D	SMF	LC
S6-Cyy-SP-ZR-D-XX	8.5	80	CWDM -1470 ~ 1610	D	SMF	LC

CWDM laser code

yy/zz	Wavelength [nm]	Clasp Color Code	yy/zz	Wavelength [nm]	Clasp Color Code
[-]		[-]	[-]		[-]
27	1270	Gray	45	1450	Brown
29	1290	Gray	47	1470	Gray

dd code	Distance
[-]	[km]
SX	0.300
LR02	2

31	1310	Gray	49	1490	Purple
33	1330	Purple	51	1510	Blue
35	1350	Blue	53	1530	Green
37	1370	Green	55	1550	Yellow
39	1390	Yellow	57	1570	Orange
41	1410	Orange	59	1590	Red
43	1430	Red	61	1610	Brown

LR	10
LR20	20
ER	40
ER60	60
ZR	80

Table 3: Distance code.

CWDM code examples:

Code	Description
S6-C27-SP-ER-D-XX	CWDM series, 1270 nm, 40 km, 0 °C to + 70 °C operational temperature
S6-C55-SP-ER-I-XX	CWDM series, 1550 nm, 40 km, -40°C to +80°C operational temperature
S6-C31-SP-ER-D-XX	CWDM series, 1310 nm, 40 km, 0 °C to + 70 °C operational temperature
S6-C33-SP-ER-D-XX	CWDM series, 1330 nm, 40 km, 0 °C to + 70 °C operational temperature
S6-C53-SP-ER-D-XX	CWDM series, 1530 nm, 40 km, 0 °C to + 70 °C operational temperature
S6-C59-SP-ER-D-XX	CWDM series, 1590 nm, 40 km, 0 °C to + 70 °C boperational temperature

Temperature code examples:

To order SFP with extended or industrial temperature, please replace the "D" mark with temperature mark in ordering number.

Code	Description
M6-D55-SP-SR-D-XX	Standard series, Multi-mode 850 nm, 300 m, 0°C to +70°C operational temperature
M6-V85-SP-SR-I-XX	Standard series, Multi-mode 850 nm, 300 m, -40°C to +80°C operational temperature
S6-D31-SP-LR-D-XX	Standard series, Single-mode 1310 nm, 10 km, 0°C to +70°C operational temperature
S6-D31-SP-LR-D-XX	Standard series, Single-mode 1310 nm, 10 km, -40°C to +80°C operational temperature