

## GSW-1005MS

**5x GbE, RJ45 + 1x Dual Rate SFP  
L2+ Managed Switch with Cable Tray**

GSW-1005MS is a managed Gigabit Ethernet CPE switch designed 5-Ports 10/100/1000Base-T RJ45 and 1 port 100/1000Base-X SFP based fiber optics. The traditional transmission distance of Gigabit Ethernet over RJ45 copper can be extended up to 100km over a fiber optics interface. GSW-1005MS has a optional cable tray that allows the installer to enclose the excess fiber within the unit, thus providing protection for the sensitive fiber at subscriber side. LEDs provide visual monitoring of Ethernet connected devices such as Ethernet home gateways, wireless access points or PC/laptop via 10/100/1000Base-T twisted pair RJ45 ports on GSW-1005MS. When GSW-1005MS is deployed as a stand-alone solution, it incorporates an easy to use Web user interface for operation, administration and maintenance both locally and remotely. All of the enabled Layer 2 features and functions of GSW-1005MS can be configured and monitored via web, CLI or SNMP management. GSW- 1005MS is particularly suitable for deploying and provisioning active Ethernet FTTX service of multi-service operators (MSO).

### Feature

- 5-Port 10/100/1000Base-T + 100/1000Base-X SFP uplink
- Supports 9.6K Bytes jumbo frame
- Supports IEEE 802.1Q tagged VLAN & Q-in-Q VLAN stacking
- Supports IEEE 802.1p priority queue
- Supports IGMP snooping v1/v2/v3
- Supports DHCP auto provisioning
- Supports dying gasp
- Fiber cable tray(optional)

### Specifications

<b>Interface</b>	5x 10/100/1000Base-T RJ-45 with 1x 100/1000Base-X SFP	<b>Management</b>	system syslog IPv6 management NTP text based configuration upload or download, IEEE 802.1ab LLDP Cisco discovery filtering (CDP) DHCP auto provisioning
<b>Switching fabric capacity</b>	12Gbps	<b>SNMP agent</b>	SNMP v1/v2c/v3, RMON Group 1,2,3 and 9
<b>Packet forwarding capacity</b>	8.928Mpps	<b>Software upgrade</b>	TFTP/HTTP
<b>Filter &amp; Forward rate</b>	14880pps at 10Mbps, 148800pps at 100Mbps, 1488000pps at 1Gbps	<b>Power Input</b>	100v~240VAC power adapter
<b>Transmission method</b>	Store and Forward Switching	<b>Operating Temperature</b>	0 ~ 50°C
<b>Standard</b>	IEEE 802.3u, IEEE 802.3z, IEEE 802.3ae, IEEE 802.3x, IEEE 802.1p, IEEE 802.1Q, IEEE 802.1ad, IEEE 802.1x, IEEE 802.1ab, IEEE 802.3az	<b>Storage Temperature</b>	-25 ~ 70°C
<b>Packet buffer</b>	4M bits	<b>Humidity</b>	5% ~ 90% (non-condensing)
<b>MAC table size</b>	8K	<b>Dimensions</b>	170 × 120 × 35mm (D × W × H)
<b>Jumbo frame size</b>	9600 Bytes	<b>Certification</b>	FCC, CE
<b>VLAN feature</b>	IEEE 802.1Q tagged VLAN (Max. 4K VLAN groups) MAC based VLAN Protocol based VLAN Private VLAN for port isolation IP subnet based VLAN, Voice VLAN VLAN translation, IEEE 802.1ad Q-in-Q		
<b>QoS feature</b>	IEEE 802.1p 8 priority queues per port, CoS based on switch port; VLAN ID; DSCP; TCP/UDP port IEEE 802.1p priority tag remarking, DSCP remarking, Port based ingress/egress rate limit		
<b>Security</b>	Port based/single/multiple IEEE 802.1x access control MAC based access control authentication RADIUS authentication, limited MAC address learning IP/MAC binding, ACL rule based filtering TACACS+, DHCP snooping/relay option 82 ARP inspection, IP source guard		
<b>IP multicasting</b>	IGMP throttling, IGMP filtering, IGMP fast leave, IGMP snooping v1/v2/v3, MVR, MLD snooping v1		
<b>Storm Control</b>	Unknown Unicast/Broadcast/Multicast storm suppression		
<b>Management</b>	Web/Telnet CLI interface Web/CLI authentication SSH v2 HTTPs port mirroring		

## Application

### Fiber to the Home Triple-Play Application

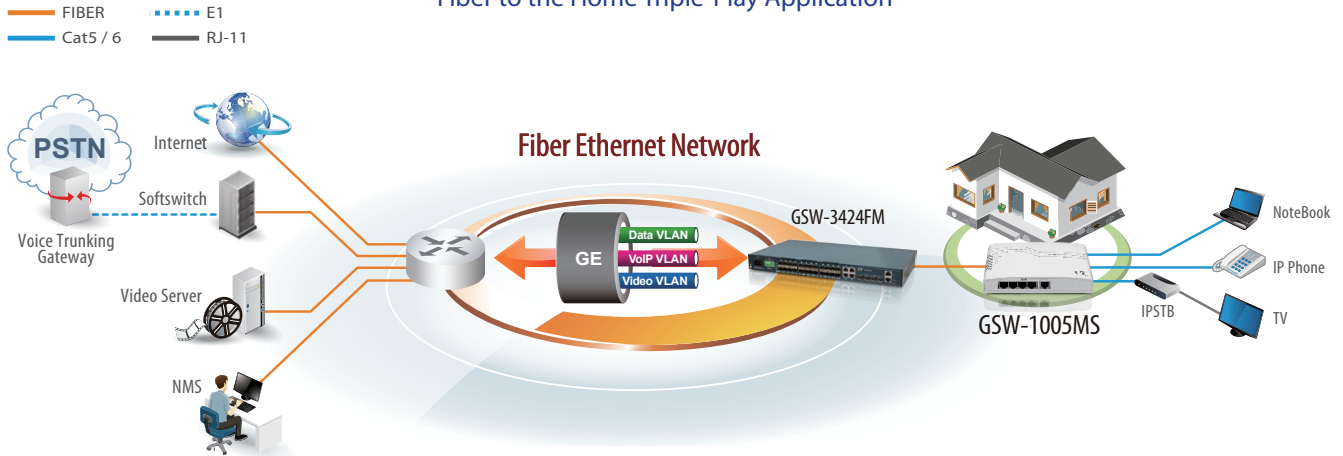

## Cable Tray Assembly

CT001 is an optional fiber tray and mounting hardware for deploying GSW-1005/2008 for residential Fiber To The Home applications. CT001 tray options is wall mounted, allowing secure termination of fiber leads.

### CT001

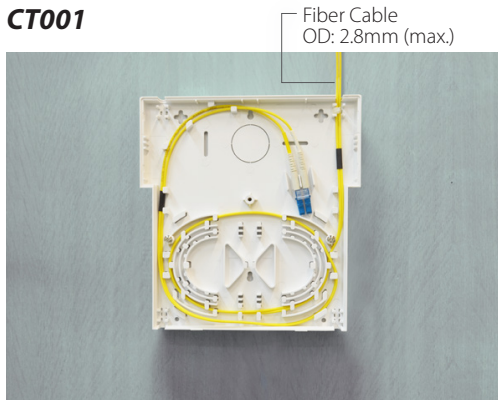

CT001 Cable Tray

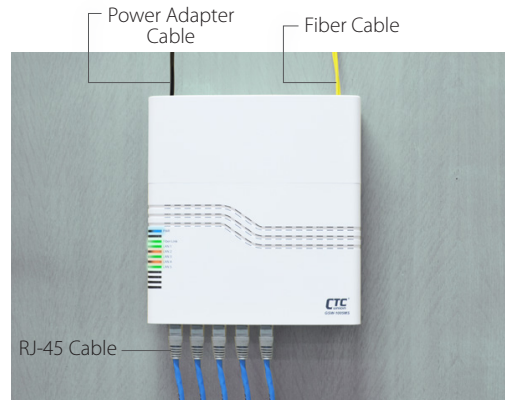

CT001 with GSW-1005MS

## Ordering Information

Model Name	Description
GSW-1005MS	5-port 10/100/1000 Base-T to 100/1000 Base-X Managed GbE Ethernet Switch (cable tray optional)

## Optinal Accessory

CT001	Cable Tray for GSW-1005MS/GSW-2008MS
-------	--------------------------------------

### Dimensions (mm)



CT001